



Audi Q8 / SQ8 e-tron

Linnamaastur, sh Sportback,
2023-2025



ainult parempoolse
rooliga

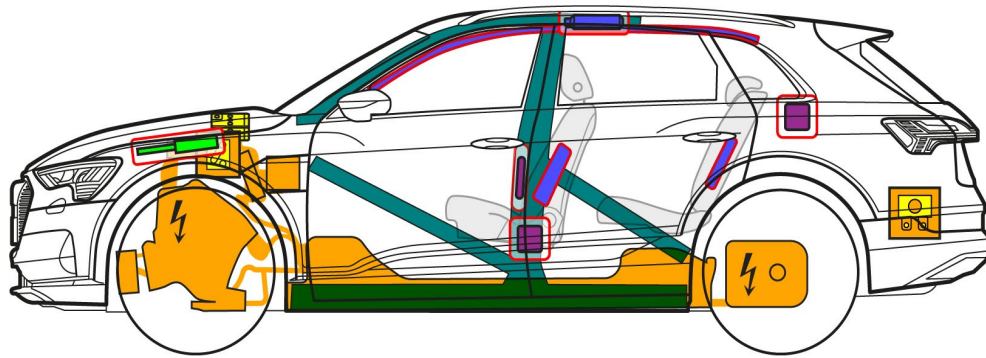
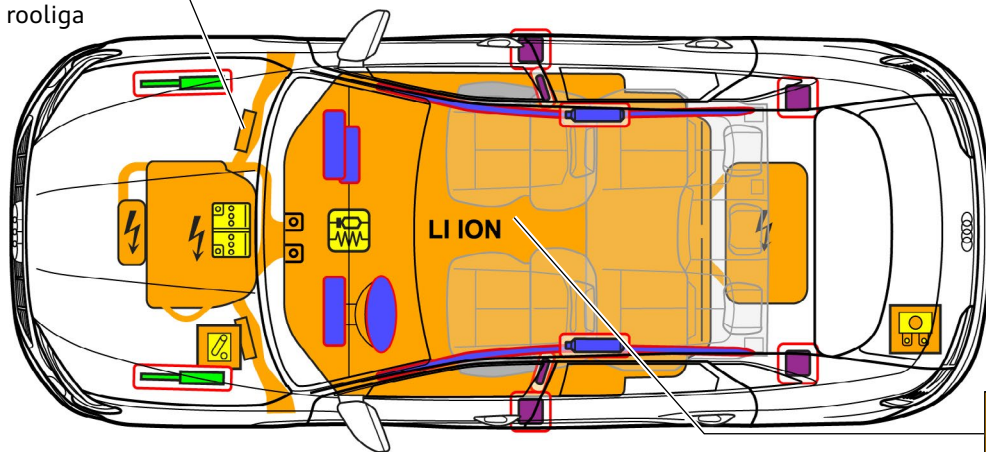

	Turvapadi		Gaasigeneraator		Turvavööpinguti		SRS juhtplokk		Gaasvedrud/ eelpingutatud vedrud
	Ülitugevad piirkonnad		Madalpingeaku		Kõrgepingeaku		Kõrgepingekaablid		Kõrgepinge lahk- lüüti, madalpin- gesüsteem
	Kaitsmete pistik, kõrgepingesüsteemi inaktiveerimine madalpingelt		Kõrgepinge- komponendid						



Audi Q8 / SQ8 e-tron

Linnamaastur, sh Sportback,
2023-2025

1. Identifitseerimine/tuvastus



Elektrisõiduk on vaikne. Näidikuploki näidikul (energiaäidikul) kuvatakse, kas elektriajam on välja lülitatud „OFF“ või töövalmis „READY“.

Laadimisühendus



Logo
(logod on valitavad)

Q8



Q8 e-tron



Q8 e-tron
Sportback

2. Fikseerimine/stabiliseerimine/tõstmine

Sõiduki fikseerimine

Vajutage parkimisnuppu „P“ ja rakendage seisupidur.

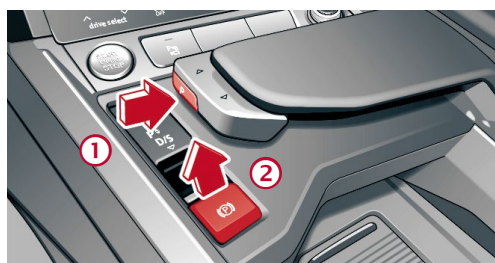

Tõstepunktid

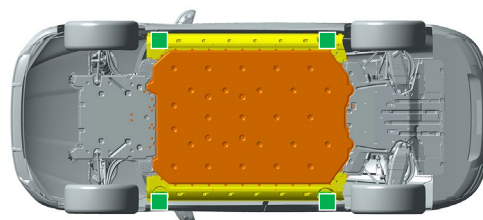

■ sobivad tõstepunktid

■ kõrgepingeaku

Lülitage süüde välja (energiaäidikul kuvatakse „OFF“)



Vajutage START-STOP nuppu ilma piduripedaali vajutamata.



Raadiovõtme asemel on võimalik kasutada ka võtmekaarti või nutitelefonirakendust.

3. Otseste ohtude vältimine / ohutuseeskirjad

Kui turvapadi avaneb avarii korral, inaktiveeritakse kõrgepingesüsteem kohe pärast turvapadja avanemise tuvastamist automaatselt. Kõrgepingesüsteem on u 20 sekundit pärast inaktiveerimist pingevaba.



Ärge puudutage, löigake läbi ega avage kahjustatud kõrgepingekomponente, -kaableid ja kõrgepingeakut. Kandke vastavat kaitsevarustust!

Muudel juhtudel saab kõrgepingesüsteemi inaktiveerida järgmiselt.

1. võimalus: mootoriruumist

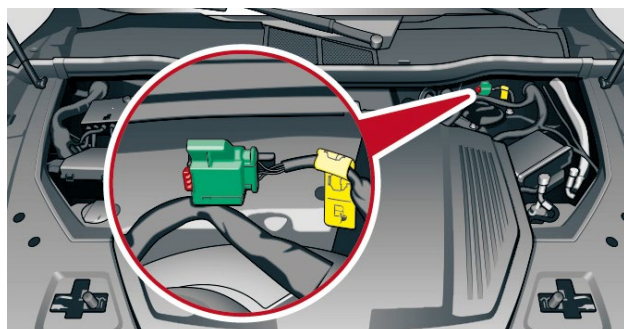
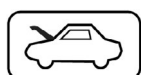

① Tõmmake punane aas välja

② Tõmmake must pistik välja





Audi Q8 / SQ8 e-tron

Linnamaastur, sh Sportback,
2023-2025

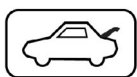

2. võimalus: (kaitsmed pagasiruumis)

Tõstke aluspõrand üles

Eemaldage luuk

Tõmmake kaitse välja

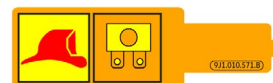
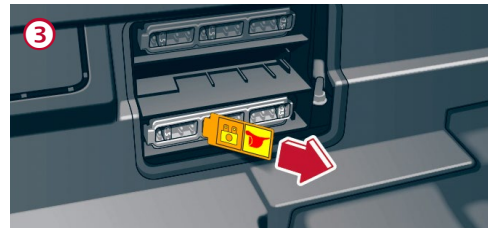
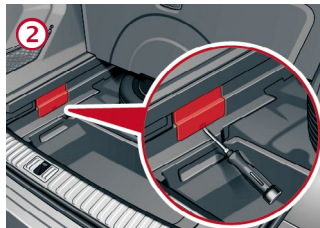
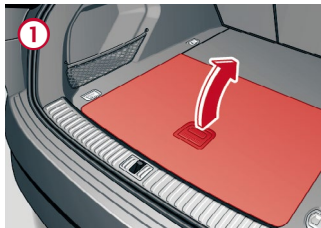

12-voldise aku lahutamine

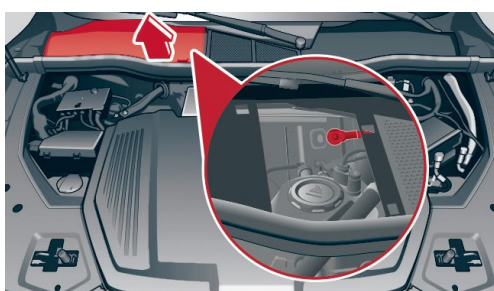
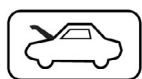

12-voldine aku asub sõiduki ees veepaagi katte all.

Aku massikaabel on kinnitatud koos kerega veepaagi seina esiküljele.

Siin saab aku massiühenduse (miinuspooluse) lahutada kere kontaktpunktist.

Laadimisjaamast lahutamine (laadimispistiku avariivabastamine)

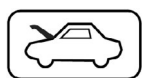

Eemaldage kate

Tõmmake kollast aasa

Tõmmake laadimispistik välja

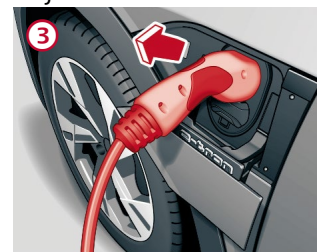
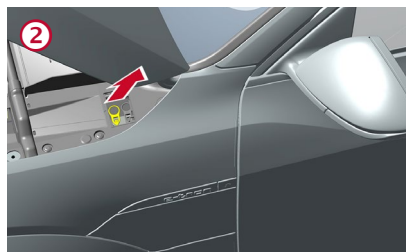
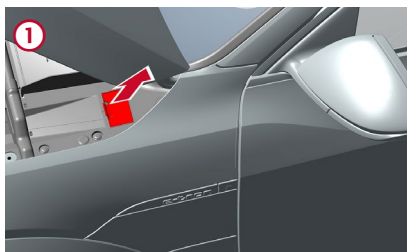

4. Juurdepääs reisijatele

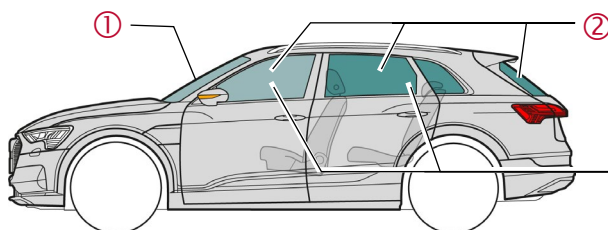

Klaasi tüübid:

- ① Komposiitklaasist turvaklaas
- ② Karastatud turvaklaas
- ③ Valikulised küljeklaasid
Komposiitklaasist turvaklaas



Audi Q8 / SQ8 e-tron

Linnamaastur, sh Sportback,

2023-2025

5. Salvestatud energia / vedelikud / gaasid / tahked ained



12 V



400 V
Liitiumioon



Aku jahutussüsteemist lekkiva jahutusvedeliku korral on oht, et kõrgepingeaku reageerib akuga termiliselt. Jälgige kõrgepingeaku temperatuuri!



6. Tulekahju korral



Liitiumioonakud võivad kahjustuste või vale kasutuse korral kohe või ka hiljem ise süttida või pärast tulekahju kustutamist uuesti süttida! Kandke vastavat kaitsevarustust!

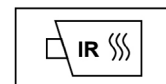

7. Vee all

Pärast auto veest välja tõstmist inaktiveerige kõrgepingesüsteem (vt 3. peatükki) ja laske veel välja voolata. Kandke vastavat kaitsevarustust!

8. Pukseerimine/transportimine/hoiustamine



Liitiumioonakud võivad ise süttida ja pärast tule kustutamist uuesti süttida! Kandke vastavat kaitsevarustust!

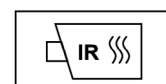

Avariisse sattunud sõidukite või kahjustatud või tavapärasest erinevate ilmingutega kõrgepingeaku korral: inaktiveerige kõrgepingesüsteem (vt 3. peatükki). Parkige sõiduk hoonetest ja teistest sõidukitest vähemalt 5 m kaugusele (isoleeritud pinnale).



Ärge pukseerige avariisse sattunud sõidukit vedavatest telgedest.

10. Kasutatud piktogrammide selgitus



Tuleohtlik



Söövitav, nahka ärritav



Tervisele ohtlik



Keskonnaohtlik



Elektrisõiduk



Kõrgepinge hoiatus



Tähelepanu, oht



Kustutada veega



Ohtlik pinge



Eemaldage nutivõti



Kasutage infra-puna-soojuskamerat



Tehke kapott lukust lahti



Tehke pakiruum lukust lahti